

CHAMP FOND

computerly/detail/quality/innovation
panel line

**CHAMP
FOND** 

研發及製造 / Design & manufactured by:

長風工業股份有限公司
CHAMP FOND MACHINERY COMPANY

台中縣后里鄉421三豐路36-1號
36-1 SAN FENG RD., HOULI, TAICHUNG, TAIWAN
Tel. 886-4-2556 7122 (7 LINES)
Fax.886-4-2556 5678
e-mail: cf-023@woodworking.com.tw
champ.fond@msa.hinet.net

●●●● 國家廣告 Campaign design 886-4-2328783 2008.07

 2008
SUMMER



**Computerly
Detail
Quality
Innovation**

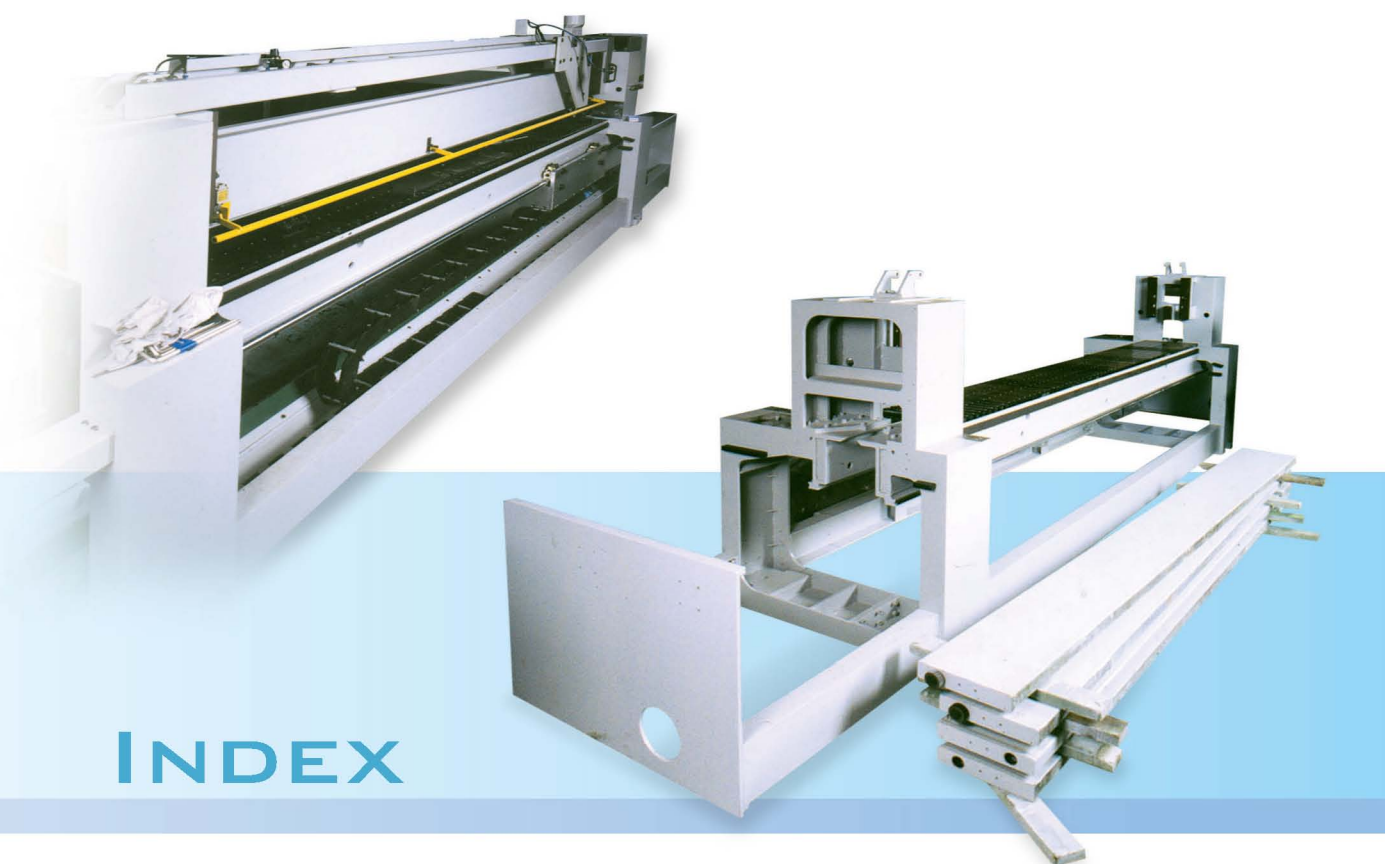
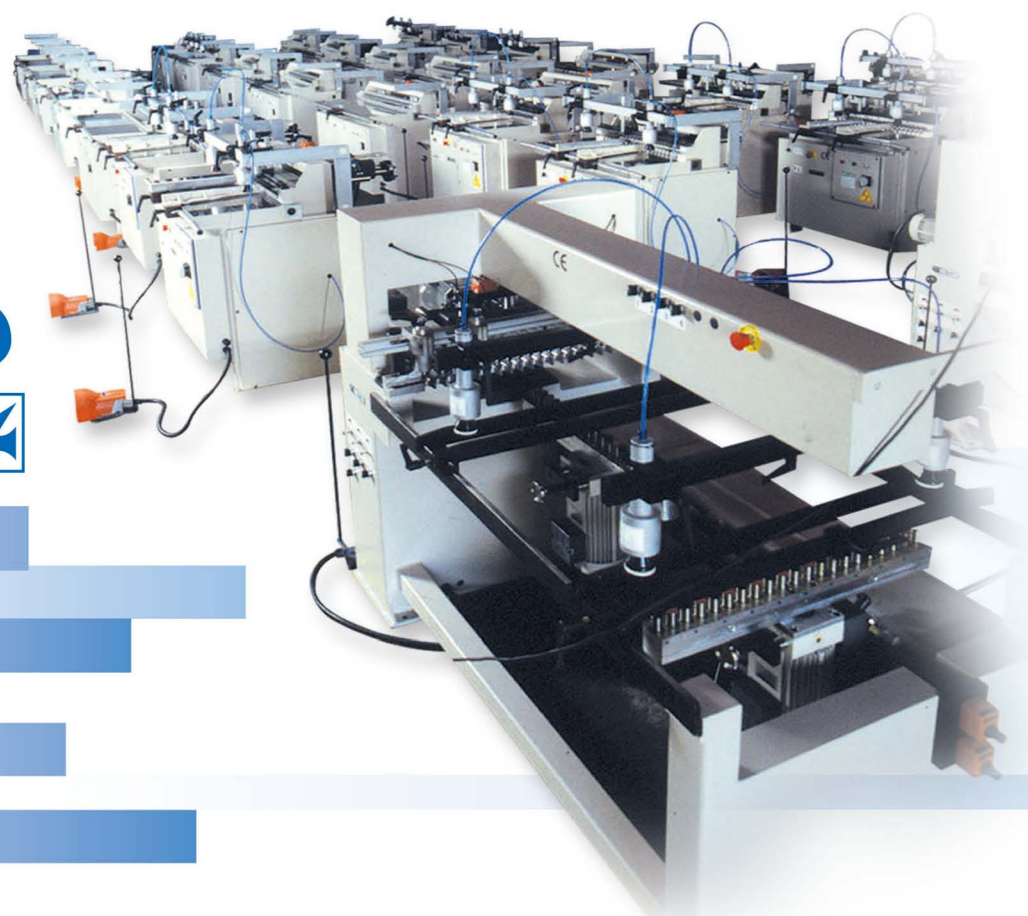

INDEX

CHAMP FOND

established in 1964 , design and manufacture fine woodworking achineries, i.e. High speed router, High speed spindle shaper, Multi spindle drilling machine, Radial arm saw etc.

Since 1997, Champ Fond launches with all new products, the PANEL LINE. We believe that the markets require high performance panel line machines, and we do develop HEAVY DUTY, HIGH SPEED panel line machines.

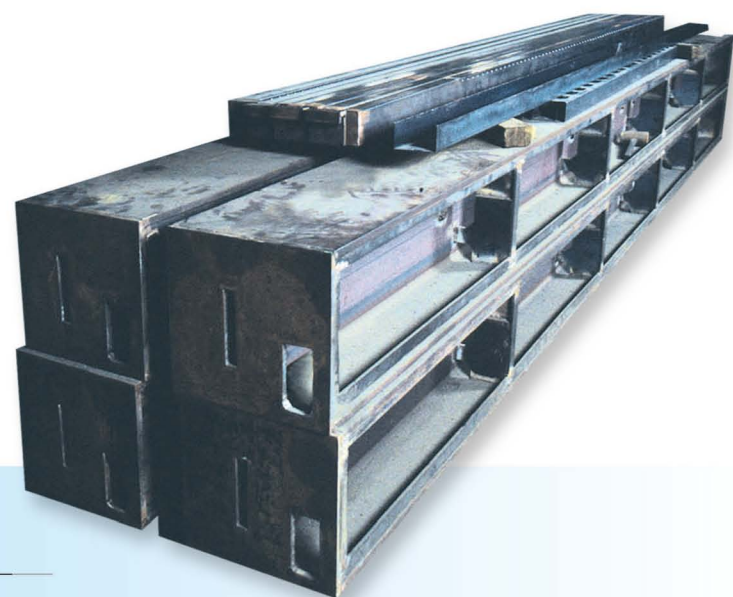

板類設備	1-2	The Panel Line equipment
板類分割設備		Panel dividing equipment
高速電腦裁板機	3-4	High Speed Panel Saw with lifting table
高速電腦裁板機	5-6-7-8	High Speed Panel Saw
板類封邊設備		Panel edge processing equipment
自動直線封邊機	9-10-11	Edgebander
封邊機特寫圖	12-13-14-15-16	Edgebander Details
封邊機說明及規格	17-18	Edgebander Profile
板類鑽孔設備		Panel boring equipment
排鑽機系列	19-20	Line Boring Machine LB-Series
組合排鑽機系列	21-22-23-24	Construction Line Boring Machine CB-Series
排鑽伙伴-組合排鑽配套設備	25-26	Line Boring Partner

Launch to high performance era.....

PROFESSIONAL PANEL LINE



Panel dividing equipment
板材分割設備



Panel boring equipment
板材鑽孔設備



Panel edge processing equipment
板材封邊設備





HS-125L / 4422

Feature:

- Rigid heavy duty machine frame.
- High speed saw carriage runs up to 150M/Min. ; optional 200M/Min.
- NC panel pusher driven by AC servo motor and speed up to 100M/Min.
- Saw blade projection programable by PLC command and range 0 ~ 125mm.

特點:

- 高強度機身。
- 配合高速台車速度可達150M/Min. ; 選項速度可達200M/Min.
- 電腦定位夾料器搭配伺服馬達速度可達100M/Min.
- 可程式控制鋸片露出高度程控0 ~ 125mm.

Option:

- Remote adjustment device for scoring saw.
- Full coverage floating table.

選配:

- 導引鋸遙控調整裝置。
- 全浮動桌面。



Picture shown model HS-125L / 4422,
with standard
1.5 M x 3 Floating tables +
Air blower 3HP x 1.



HS-125

Feature:

- Rigid heavy duty machine frame.
- High speed saw carriage runs up to 150M/Min. ; optional 200M/Min.
- NC panel pusher driven by AC servo motor and speed up to 100M/Min.
- Saw blade projection programmable by PLC command and range 0 ~ 125mm.

特點:

- 高強度機身。
- 配合高速台車速度可達150M/Min. ; 選項速度可達200M/Min.
- 電腦定位夾料器搭配伺服馬達速度可達100M/Min.
- 可程式控制鋸片露出高度程控0 ~ 125mm.

Option:

- Remote adjustment device for scoring saw.
- Full coverage floating table.

選配:

- 導引鋸遙控調整裝置。
- 全浮動桌面。



Picture shown model HS-125 / 4443, with optional 2.1 M x 1 + 1.5 M x 3 Floating tables + Air blower 5HP x 1 and Extra grippers.

Specification:

Model No.	HS-125 / 3231	HS-125 / 4443	型 號
Saw carriage speed	150 M/Min. (Opt. 200M/Min)		台車最快速度
Main saw motor	20HP (Opt. 30HP, 40HP variable speed)		主鋸片馬達
Scoring saw motor	2HP		導引鋸馬達
Saw carriage driven motor	1HP		台車往復馬達
Gripper unit speed	100 M/Min.		電腦夾料器最快速度
NC panel pusher motor	AC servo motor		電腦夾料器馬達種類
Maximum panel width	3,250mm	4,450mm	最大板寬
Maximum panel length	3,100mm	4,300mm	最大板長
Saw blade projection	Programmable 0 ~ 125 mm		鋸片露出高度
Main saw speed	3,850rpm		主鋸片轉速
Scoring saw speed	7,000rpm		導引鋸轉速
Compress air required	7 ~ 10 Kg/cm ² (100 ~ 147 PSI)		壓縮空氣需求
Net weight	4,800 kg (10,560LB)	5,800 kg (12,760LB)	機器淨重
Gross weight, pallet only	5,600 kg (12,320LB)	6,800 kg (14,960LB)	總重, 使用棧板
Packing dimensions	20 feet container required	40 feet container required	包裝尺寸
Overall dimensions	525 x 590 x 170 cm	645 x 710 x 170 cm	外觀尺寸
Model No.	HS-125L / 3222	HS-125L / 4422	型 號
Lifting table size	3.2M x 2.2M	4.4M x 2.2M	升降台尺寸
Lifting table height	H=0.56M (Opt. H=1.08M)		升降台高度
Lifting table load	Payload limited 2,000 kg		升降台負載
Net weight	9,000 Kg (19,800 LB)	10,200 Kg (22,440 LB)	機器淨重
Gross weight, pallet only	10,300 Kg (22,660 LB)	11,700 Kg (25,740 LB)	總重, 使用棧板
Packing dimensions	40 feet container required		包裝尺寸
Overall dimensions	525 x 1100 x 170 cm	645 x 1100 x 170 cm	外觀尺寸

Opt. = Optional (選項配備)

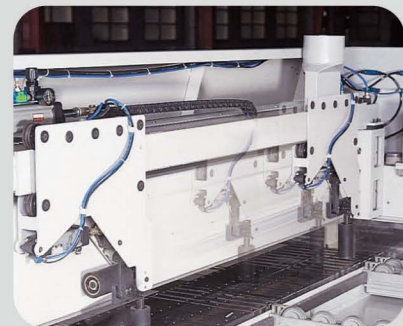

Independent side press roller system, automatic align the cross cutting at right angle.

獨立側壓輪系統, 自動對正橫切角度。



Hardened rail and heavy duty rack-pinion system.

硬化處理滑軌及重型齒條一齒輪系統。

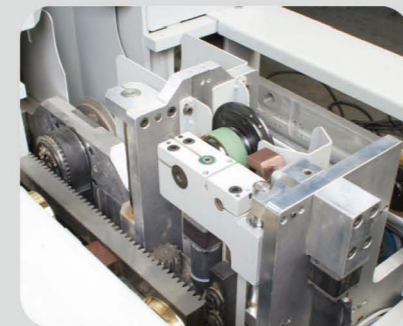

Remote adjustment device for scoring saw. (option)

導引鋸遙控調整裝置。(選項)

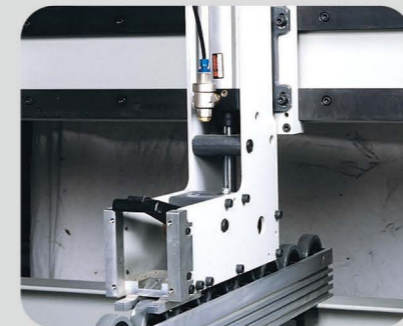

Extra size floating gripper with close-loop clamping force sensor.

大型浮動夾爪附壓力確保裝置。

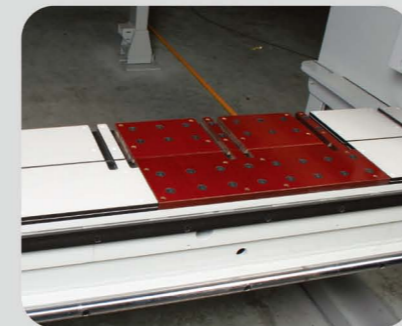

Full coverage floating table. (option)

全浮動桌面。(選項)

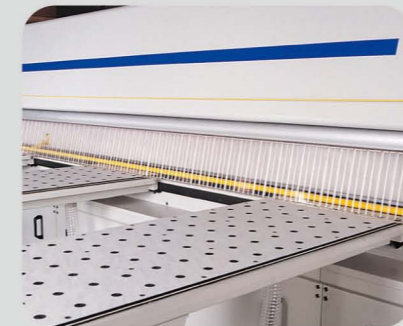

Floating table, modular bakelite working table and precision roller table.

浮動檯面, 電木桌面及滾輪架, 可充分保護板料免於刮傷。

Computerly
Detail
Quality
Innovation

CHAMP FOND Edgebänder
自動直線封邊機

EL-60
EL-70
EB-7B

Feature:

- Rigid heavy duty machine frame, high performance horizontal end trim unit, up-down trim unit, chamfer trim unit, scraping unit, grooving unit, contour copying unit and versatile buffing unit.
- Working speed up to 30M/Min. as optional.

特點:

- 高強度機身，無撞機疑慮之水平式前後修單元，重型上下修倒角修刮刀溝槽單元，高性能四馬達曲面仿型單元，萬向拋光單元。
- 高速機型可達每分鐘三十米。



◀ **EL-60**
Edgebänder with grooving unit
自動封邊機附溝槽單元

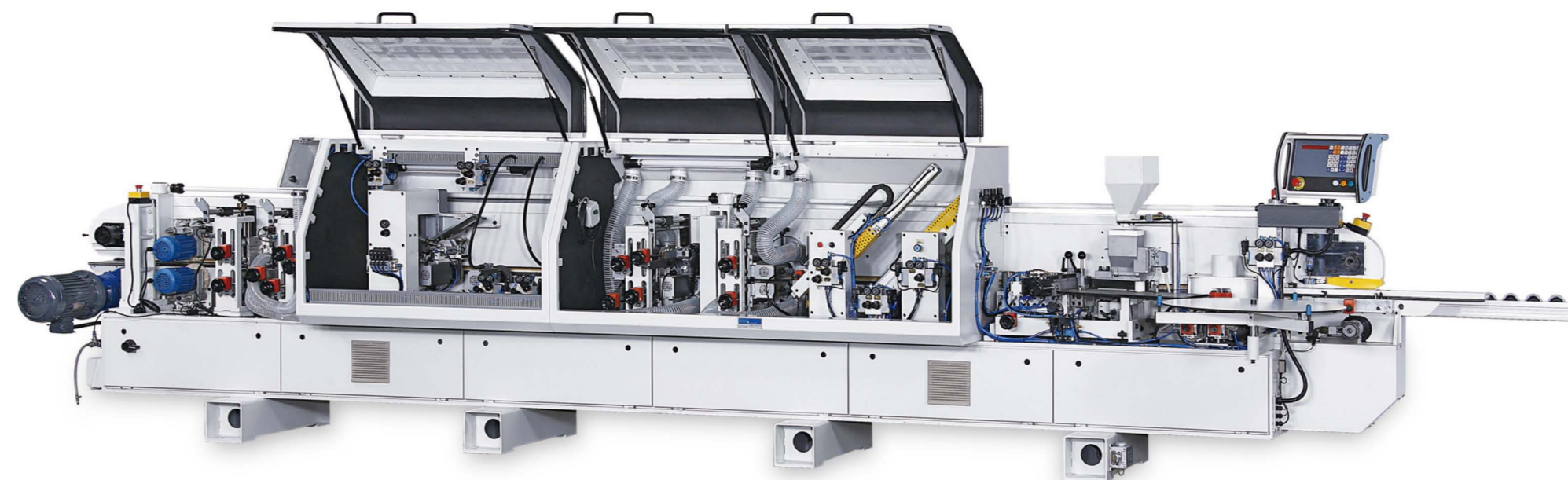

▲ **EL-70**
Edgebänder with contour copy unit
自動封邊機附仿角單元

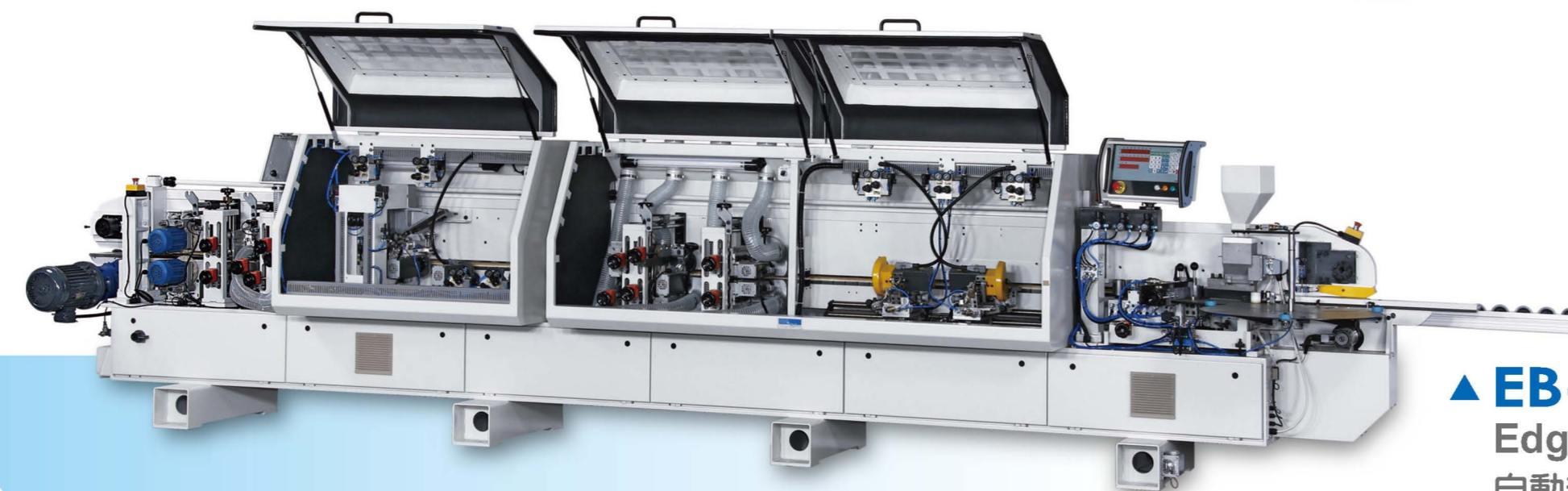

▲ **EB-7B**
Edgebänder with contour copy unit
自動封邊機附仿角單元

Computerly
Detail
Quality
Innovation



Color Human-Machine-Interface (HMI) simplifies the learning curves of operator. 彩色人機介面簡化操作人員之學習曲線。



The rigid aluminum alloy #7075-T6 saw cage, offer maximum cutting ability. 高剛性航太鋁合金台車，提供最佳切削能力。

8

9

PROFESSIONAL PANEL LINE

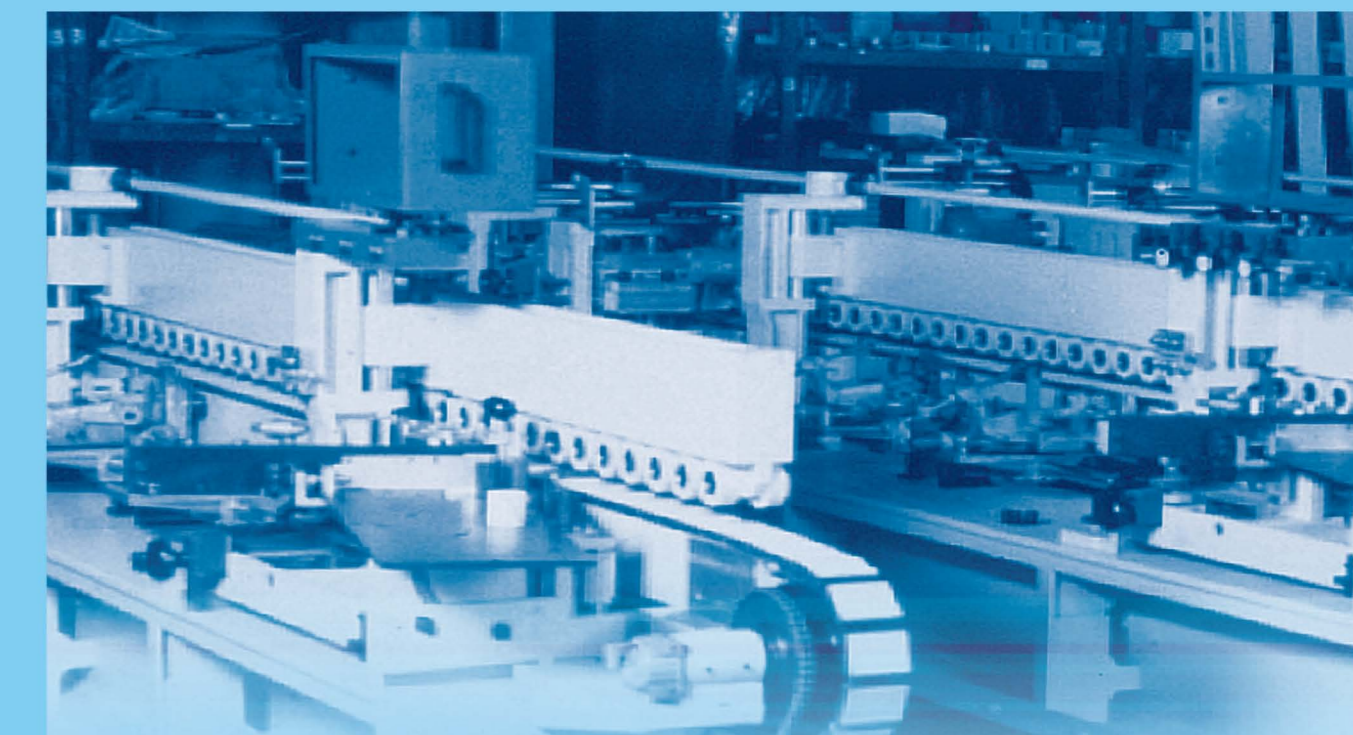

EL-series
EL-60, EB-6B
Edgebänder with grooving unit
自動封邊機附溝槽單元

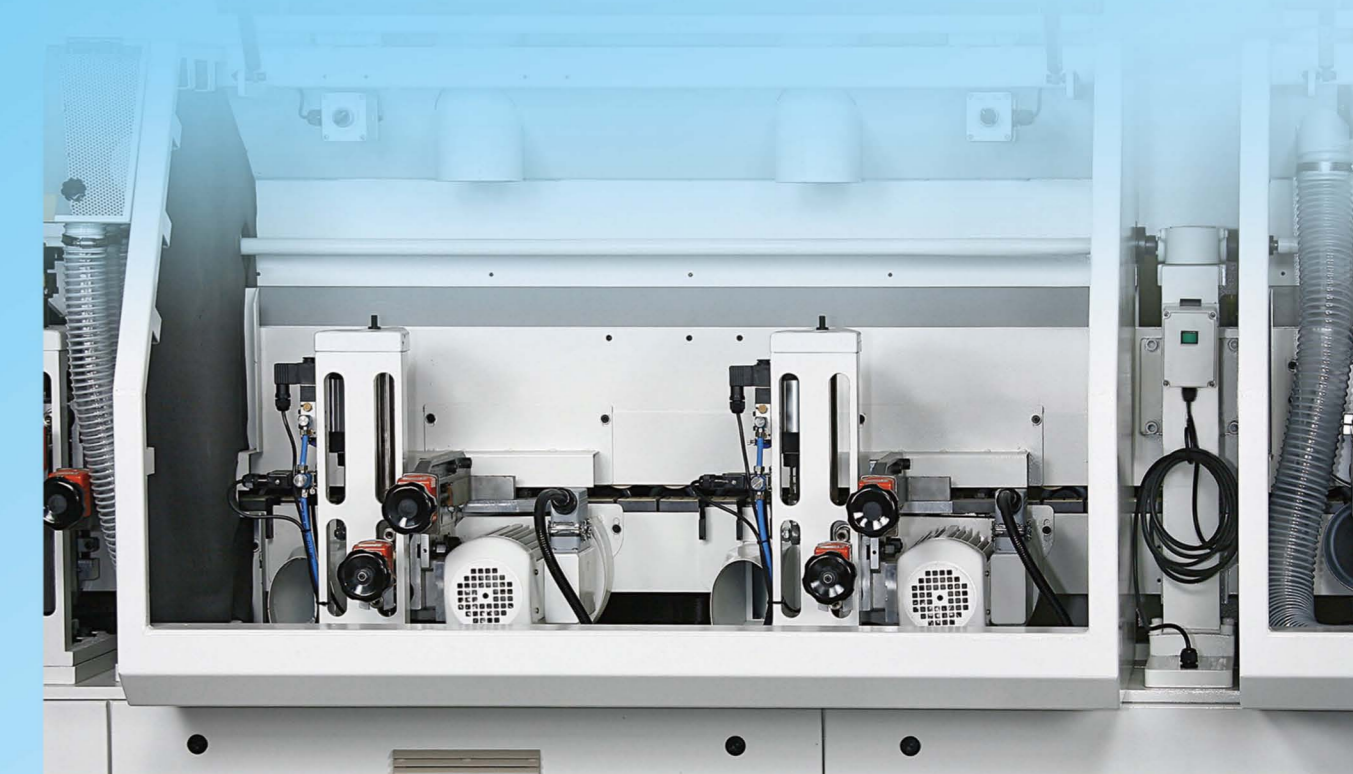

10

PROFESSIONAL PANEL LINE

11

CHAMP FOND Edgebander Details
封邊機特寫圖

**EB-series
EB-7B**
Edgebander
with contour copy unit
自動封邊機附仿角單元

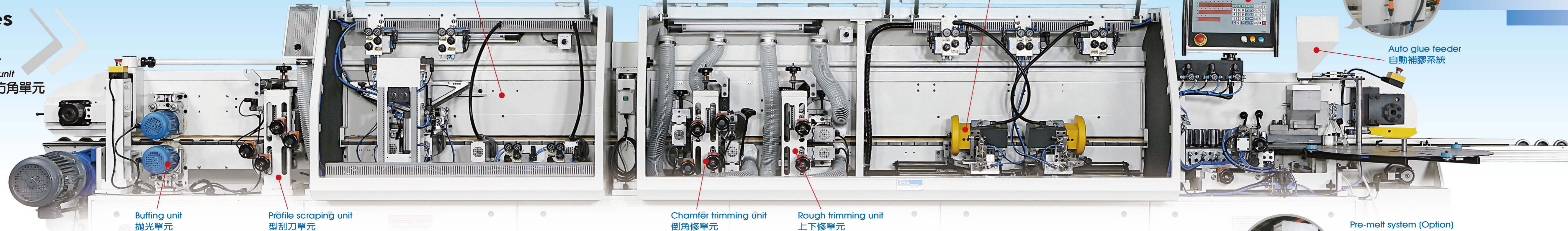

**EL-series
EL-70**
Edgebander
with contour copy unit
自動封邊機附仿角單元

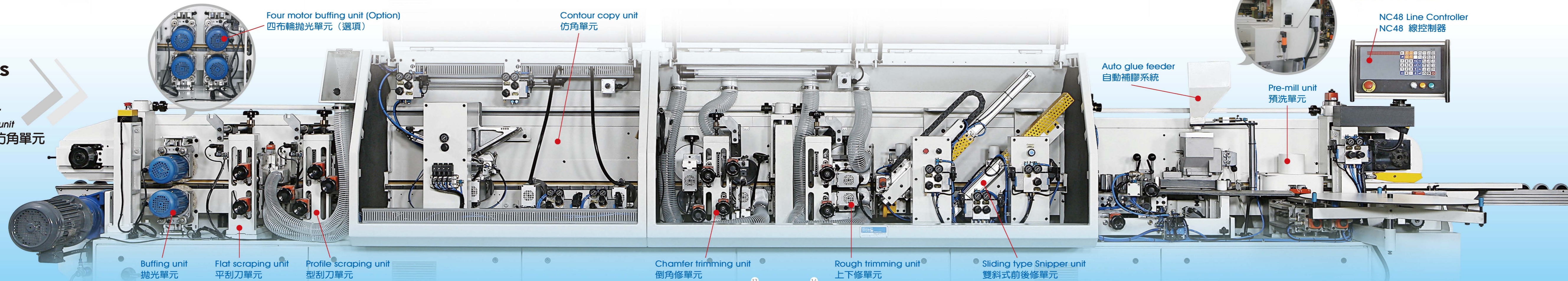

Computerly
Detail
Quality
Innovation

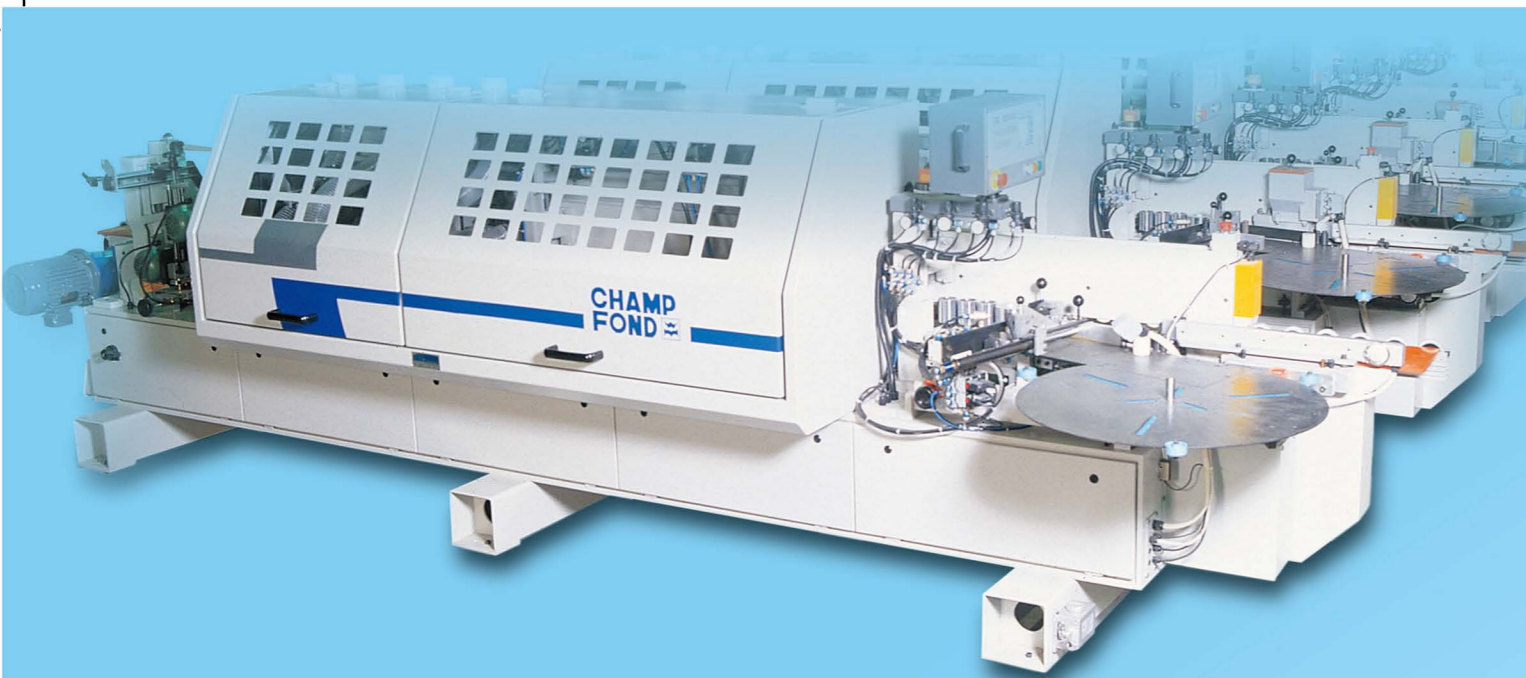

- ▲ Precision & hardened rail, dual material embedded chain pad & extra size chain. 精密硬化滑軌，雙材質嵌入式墊片，重型鏈條。
- High tension steel pressure beam, offer stable & continue pressure force. 高張力壓樑，提供穩定及持續性之壓著力。
- Smooth out board rollers rail, offer gender support force. 平滑表面之輔助滾輪架，提供溫和之支撐力道。



Pre-heat fence (Opt.) 預熱靠板 (選項)

Pressure beam system:
壓力樑系統：

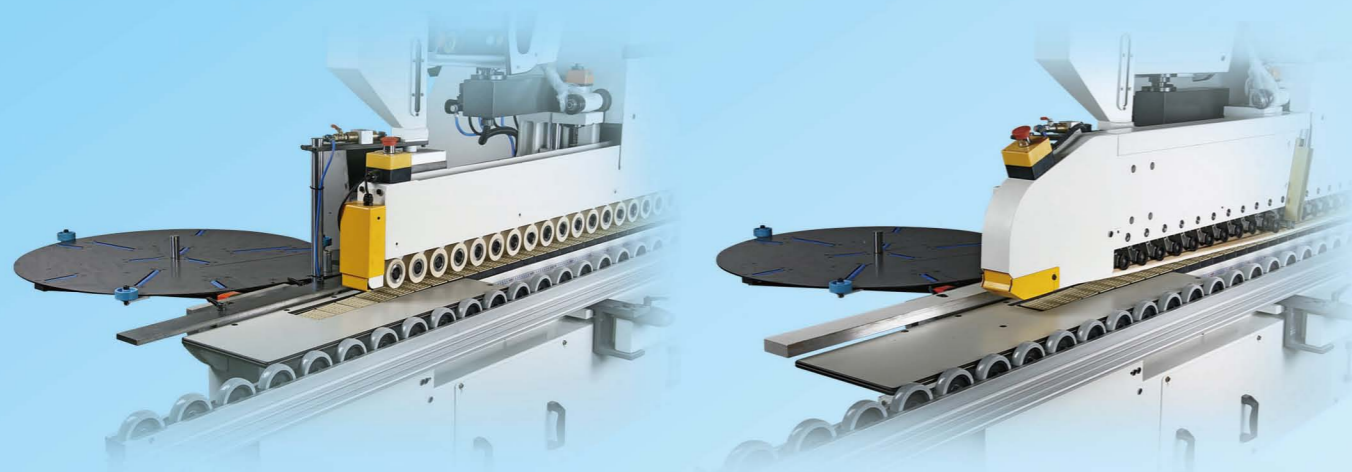

Left picture shown ROLLER TYPE for EB-2, EB-3. 左圖展示膠輪壓力樑。

Right picture shown BELT TYPE for EL-series & EB-5B, EB-6B, EB-7B. 右圖展示橡膠皮帶(另稱“履帶型”)壓力樑。

CHAMP FOND Edgebander Profile

封邊機規格 · 說明

Computerly
Detail
Quality
Innovation



Edgebander 自動封邊機

Machine frame

- Rigid machine frame. Flexible for installing varies of working unit.
- Ten minutes startup time for hot melt glue system.
- Require minimum standby time.
- Perss roller unit comes with linear ball bearings.
- Heavy duty chain with durable 80mm x 60mm chain pads.
- Ball bearing installing onto each press rubber rollers.

機身規格

- 重型標準機身，可配合需求彈性配置不同加工單元。
- 十分鐘快速熱熔膠系統熱機時間，節省開機等待時間。
- 選條壓合輪全面使用線性軸承，確保動作順暢。
- 重型動力級鍊條，配合橡膠嵌式墊片。
- 雙排交錯式橡膠壓力輪，每組裝用滾珠軸承兩枚。

Working unit

- End trimming unit: 18 ~ 24M/Min. with LINE controller.
- Rough trimming unit: 600W x 2
- Chamfering unit: 600W x 2
- Scraping unit: scraper x 2
- Grooving unit: 7.5HP x 1 or 7.5HP x 2
- Contour copy unit: 600W x 4
- Buffing unit: 0.5HP x 2

加工單元

- 前後修單元：速度每分鐘18 ~ 24M/Min. 使用先進管線控制
- 高速前後修單元：速度每分鐘30米
- 上下修單元：高頻馬達600W x 2
- 倒角修單元：高頻馬達600W x 2
- 刮刀座單元：重型刮刀柄 x 2
- 溝槽單元：高頻馬達7.5Hp x 1或7.5HP x 2
- 仿角單元：高頻馬達600W x 4
- 拋光單元：感應馬達0.5HP x 2

EB-2 / EB-3

自動封邊機 Edgebander

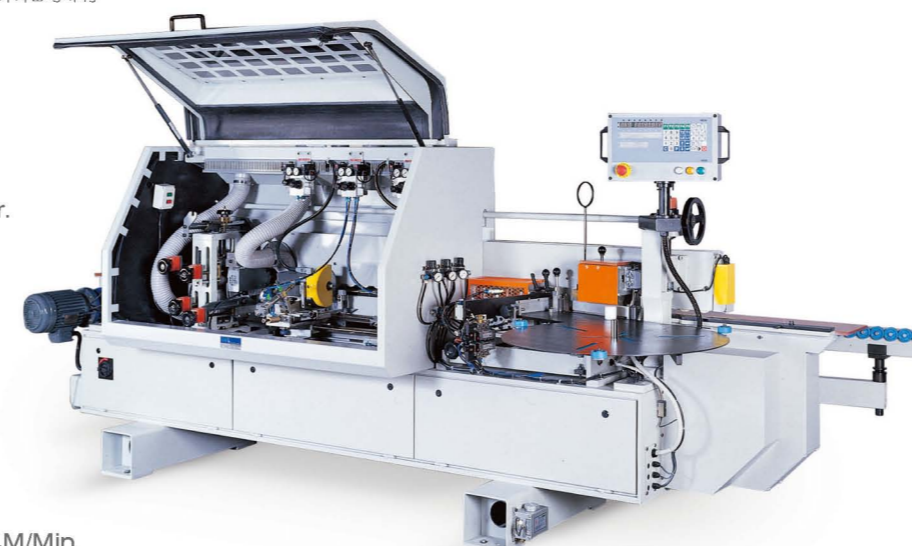
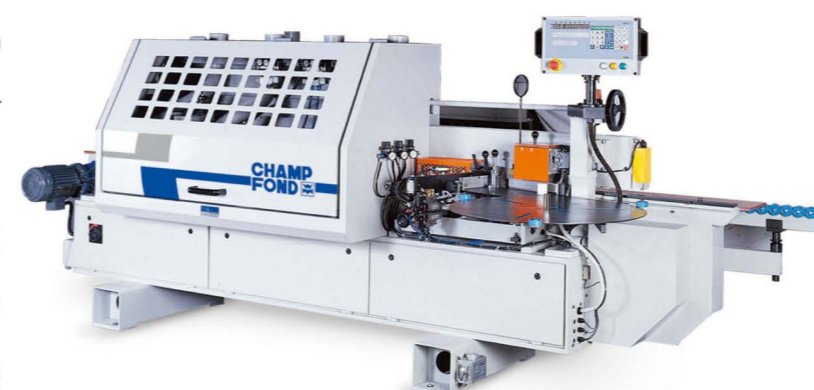

Specification:

Model No.	EB-2	EB-3	EB-5B	EL-50	EB-6B	EL-60	EB-7B	EL-70	型號
Controller	NC-32		NC-32	NC-48	NC-32	NC-48	NC-32	NC-48	控制器
Conveyor speed	18 M/min.		Variable speed 18 ~ 24 M/Min. (Opt. 30 M/Min.)						輸送帶速度
Pressure beam Type	ROLLER TYPE		BELT TYPE						壓力樑種類
Conveyor motor	2 HP		3 HP		5 HP				輸送帶馬達
Net weight	2,400 Kg	2,500 Kg	2,800 Kg		3,200 Kg				機器淨重
Gross weight	2,600 Kg	2,700 Kg	3,000 Kg		3,400 Kg				機器總重
Packing dimensions	115 x 480 x 175 cm		115 x 585 x 175 cm		115 x 730 x 175 cm				包裝尺寸
Overall dimensions	250 x 480 x 195 cm		250 x 585 x 195 cm		250 x 730 x 195 cm				外觀尺寸
Machine frame length	3 Meter		4.5 Meter		6 Meter				機身長度
Pre-mill unit				○		○		○	預洗單元
Sliding type Snipper unit				●		●		●	雙斜式前後修單元
Tacking type Snipper unit	○	●	●		●		●		水平前後修單元
Rough trimming unit			●	●	●	●	●	●	上下修單元
Chamfer trimming unit		●	●	●	●	●	●	●	倒角修單元
2 nd Chamfer trimming unit	○								第二倒角修單元
Profile scraping unit			●	●	●	●	●	●	型刮刀單元
Flat scraping unit				○		○		○	平刮刀單元
Grooving unit					●	●			溝槽單元
2 nd grooving unit					○	○			第二溝槽單元
Contour copy unit							●	●	仿角單元
Sanding unit	○	○	○						砂磨單元
Buffing unit	○	●	●	●	●	●	●	●	拋光單元
Tape PVC 0.5mm	✓	✓	✓	✓	✓	✓	✓	✓	加工PVC 0.5 mm
Tape veneer 1.0mm	✓	✓	✓	✓	✓	✓	✓	✓	加工木箔片 1mm
Tape ABS 1.0mm~3.0mm			✓	✓	✓	✓	✓	✓	加工ABS 3 mm
Working height	12 ~ 50mm (Opt. 12 ~ 60mm)								加工高度
Minimum working length	150mm								最小加工長度
Minimum working width	150mm								最小加工寬度
Compress air required	7 ~ 10 Kg/cm ² (100 ~ 147 PSI)								壓縮空氣需求

- : Standard working unit. (標準配備)
- : Optional working unit, subject to available of free space. (選項配備但需考慮可用空間)
- ✓ : Applicable jobs with identify materials. (可應用邊條材料)

All specifications and design characteristics shown are subject to change without prior notice. 尺寸規格若有所變更恕不另行通知。

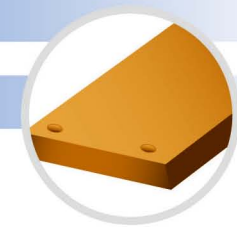

Feature:

1. Solid one piece base.
2. Bores from the bottom side of the work piece, which gives a uniform and accurate depth of bore because the depth is not affected by variations in board thickness. Secondly, this advantage also prevents the external surfaces of the work piece from being marred by the METAL worktable.
3. Independent pneumatic pedals operation require minimum maintenance.
4. Convenient front location of the control panel allows easy adjustment of the pneumatic speed regulator and boring methods selection.
5. All motors are activated only during boring which minimizes the power consumption & noise.

特點：

1. 單件式機體經久耐用
2. 從下側及定規側鑽孔所以鑽孔深度不受板厚變動影響 額外好處是木板正面在加工時不與金屬桌面接觸所以不易刮傷 木屑則自然落下不會堆積在木板上。
3. 獨立腳踏開關 操作簡單維修容易
4. 便利的設計 速度調整器及鑽孔模式選擇都位於機器前面
5. 電動馬達僅在鑽孔行程中啟動 增加使用壽命同時可降低電力消耗及噪音

LB-21i / 27i / 35i

單排鑽孔機
Single Line Boring Machine



圓筒型快速接頭
配合超精密排鑽主軸，鑽孔時絕無擴孔或橢圓孔現象。
●專利申請中●

Cylinder type quick chuck.



LBS-54 訂製型鑽孔機

Custom-built Special Line Boring Machine (Available on request)

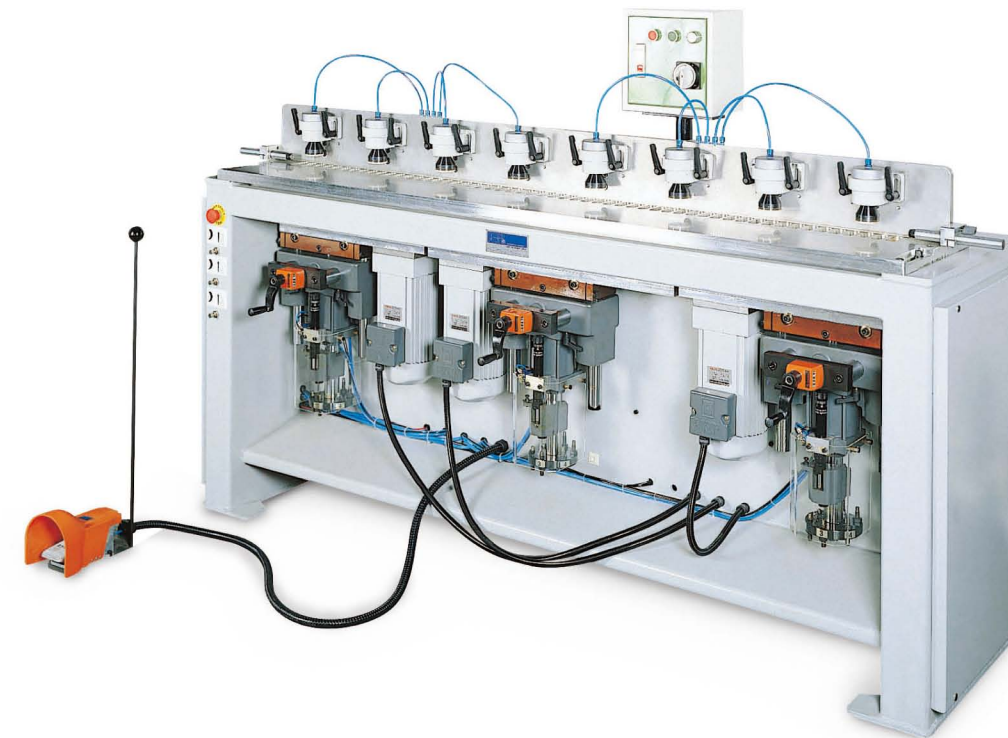

Specification:

Model No.	LB-21i	LB-27i	LB-35i	LB-35Bi	型號
Motor	4HP/3ph			4HP/3phx2	馬達
Spindle speed	2,875 rpm (50Hz), 3,450rpm (60Hz)				馬達轉速
Table size	880 x 500mm	1,060 x 500mm	1,320 x 500mm		工作桌面尺寸
Table height	890mm				工作桌面高度
Maximum work piece size	880 x 3,000mm	1,060 x 3,000mm	1,320 x 3,000mm		最大工作物尺寸
Maximum thickness of panel	80mm				最大工作物厚度
Boring method	Pneumatic system 氣壓系統				鑽孔方式
Maximum boring depth	Adjustable max. 75 mm 可調整最深75毫米				鑽孔深度
Maximum working speed	0 ~ 15 cycle/min.				操作速度
Quick chuck	LB-QUICK CHUCK x 12PCs 快速接頭12枚				快速接頭
Pitch of spindles	32mm				排鑽軸心節距
No. of spindles	21 PCs	27 PCs	35 PCs		鑽軸數量
Distance between 1 st & last spindles	640mm	832mm	1,088mm		頭尾孔距離
Net weight	318 Kg (600 LB)	345 Kg (650 LB)	378 Kg (700LB)	410 Kg (770 LB)	機器淨重
Gross weight	400 Kg (780 LB)	436 Kg (850 LB)	478 Kg (850 LB)	510 Kg (990 LB)	機器毛重
Packing dimensions	115 x 83 x 115 cm	135 x 83 x 115 cm	160 x 83 x 115 cm		包裝尺寸
Overall dimensions	115 x 120 x 140 cm	135 x 120 x 140 cm	160 x 120 x 140 cm		外觀尺寸

*All specifications and design characteristics shown are subject to change without prior notice.
尺寸規格若有所變更恕不另行通知。

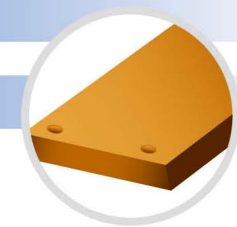

Feature:

1. Solid one piece base.
2. Bores from the bottom side of the work piece, which gives a uniform and accurate depth of bore because the depth is not affected by variations in board thickness. Secondly, this advantage also prevents the external surfaces of the work piece from being marred by the METAL worktable.
3. Independent pneumatic pedals operation require minimum maintenance.
4. Convenient front location of the control panel allows easy adjustment of the pneumatic speed regulator and boring methods selection.
5. All motors are activated only during boring which minimizes the power consumption & noise.

特點：

1. 單件式機體經久耐用
2. 從下側及定規側鑽孔所以鑽孔深度不受板厚變動影響 額外好處是木板正面在加工時不與金屬桌面接觸所以不易刮傷 木屑則自然落下不會堆積在木板上
3. 獨立腳踏開關 操作簡單維修容易
4. 便利的設計 速度調整器及鑽孔模式選擇都位於機器前面
5. 電動馬達僅在鑽孔行程中啟動 增加使用壽命同時可降低電力消耗及噪音



• Control panel (Left)
左控制面板



• Control panel (Right)
右控制面板



• Flap type side fence
可掀式側定規 (左右各一)



• Retractable main fence
可滑縮式主定規



• Dust chute
吸塵口



• Slope for dust collect
斜坡輔助集塵

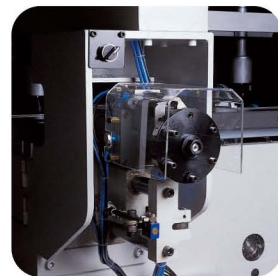

• Six position main fence stopper
六段主定規定位器

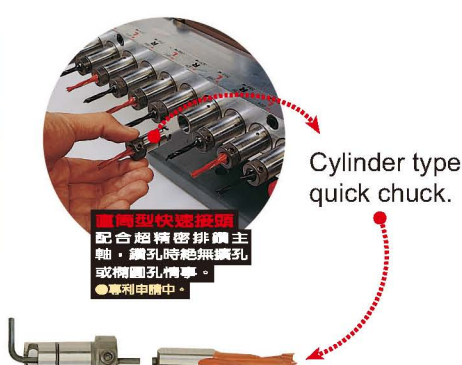

Cylinder type quick chuck.

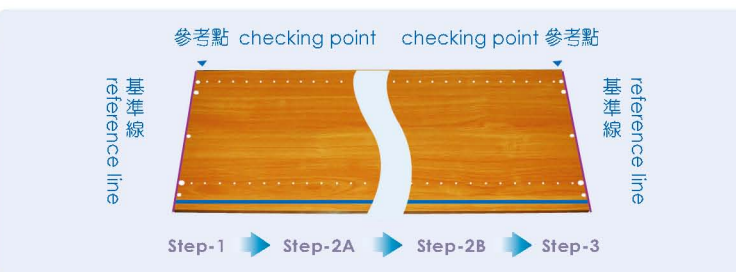

Specification:

Model No.	CB-126	型號
Motor	4HP/3ph x 6 PCs	馬達
Motor speed	2,875rpm (50Hz) 3,450rpm (60Hz)	馬達轉速
Table size	1,650mm x 850mm	工作桌面尺寸
Table height	950mm	工作桌面高度
Maximum work piece size	3,000mm x 1,230mm	工作最大尺寸
Maximum thickness of panel	80mm	工作最大厚度
Boring method	Pneumatic-hydraulic combination system 氣動油壓穩速複合系統	鑽孔方式
Maximum boring depth	6 step selector, max. 70mm 六段深度定位器, 最深70毫米	鑽孔深度
Working speed	0 ~ 15 cycle/min 每分鐘最快15循環	操作速度
Quick chuck	LB-QUICK CHUCK x 12 PCs 快速接頭 12枚	快速接頭
Compress air required	7 ~ 10Kg/cm ² (100 ~ 147PSI)	壓縮空氣
Pitch of spindles	32mm	排鑽軸心節距
No. of total spindles per machine	126 PCs	鑽軸數量
Parallel gear head used	GH-LB-21c32 x 4 PCs	平行孔排鑽規格
Auxiliary gear head used	GH-LB-21L32 x 2PCs	輔助孔排鑽規格
Distance between 1st & last holes	21 x 2 holes (1,312mm) 四十二孔雙排	排鑽最大孔距
Max. Distance between parallel lines	224mm ~ 448mm	排鑽間距
Net weight	1,600 Kg (3,520LB)	機器淨重
Gross weight	1,800 Kg (3,960LB)	機器毛重
Packing dimensions	311 x 152 x 161 cm	包裝尺寸
Overall dimensions	300 x 140 x 145 cm	外觀尺寸

*All specifications and design characteristics shown are subject to change without prior notice. 尺寸規格若有所變更恕不另行通知。

CB-126 側板專用六排鑽 Construction Line Boring Machine for Side Panel



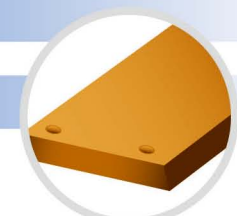

Feature:

1. Solid one piece base.
2. Bores from the bottom side of the work piece, which gives a uniform and accurate depth of bore because the depth is not affected by variations in board thickness. Secondly, this advantage also prevents the external surfaces of the work piece from being marred by the METAL worktable.
3. Independent pneumatic pedals operation require minimum maintenance.
4. Convenient front location of the control panel allows easy adjustment of the pneumatic speed regulator and boring methods selection.
5. All motors are activated only during boring which minimizes the power consumption & noise.

特點：

1. 單件式機體經久耐用
2. 從下側及定規側鑽孔所以鑽孔深度不受板厚變動影響 額外好處是木板正面在加工時不與金屬桌面接觸 所以不易刮傷 木屑則自然落下不會堆積在木板上
3. 獨立腳踏開關 操作簡單維修容易
4. 便利的設計 速度調整器及鑽孔模式選擇都位於機器前面
5. 電動馬達僅在鑽孔行程中啟動 增加使用壽命同時可降低電力消耗及噪音



Two top panel on working table.
兩片頂底板可同時加工。



Stopper for top panel's checking point.
球面靠點確保參考點正確。



Angular cylinder clamp, assure the clamping direction and clamping force.
角度缸提供雙向壓著力，可確保加工基準線正確。



Front extension roller table for extra size top panel.
超寬槽可使用延伸滾輪架。



Symetry left & right stoppers, easy to use.
左右對稱球面靠點 可簡化操作。

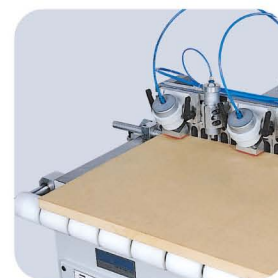

Cylinder type quick chuck.



基準線
reference line

參考點
checking point



●專利申請中●

Specification:

Model No.	CB-70	型號
Motor	4HP/3ph x 2 PCs	馬達
Motor speed	2,875rpm (50Hz) 3,450rpm (60Hz)	馬達轉速
Table size	1,500mm x 400mm	工作桌面尺寸
Table height	890mm	工作桌面高度
Maximum work piece size	1,500mm x 1,150mm	工作最大尺寸
Maximum thickness of panel	30mm	工作最大厚度
Boring method	Pneumatic-hydraulic combination system 氣動油壓穩速複合系統	鑽孔方式
Maximun boring depth	6 step selector, max. 70mm 六段深度定位器, 深70毫米	鑽孔深度
Working speed	0 ~ 15 cycle/min. 每分鐘最快15循環	操作速度
Quick chuck	LB-QUICK CHUCK x 12 PCs 快速接頭 12枚	快速接頭
Compress air required	7 ~ 10 Kg/cm ² (100 ~ 147PSI)	壓縮空氣
Pitch of spindles	32mm	排鑽軸心節距
No. of total spindles per machine	70 PCs	鑽軸數量
Parallel gear head used	GH - LB - 35L32 x 2 PCs	平行孔排鑽規格
Distance between 1st & last holes	35 holes (1,088mm) 三十五孔雙排	排鑽最大孔距
Net weight	900 Kg (1,980LB)	機器淨重
Gross weighth	1,100 Kg (2,420LB)	機器毛重
Packing dimensions	170 x 130 x 120 cm	包裝尺寸
Overall dimensions	175 x 135 x 135 cm	外觀尺寸

*All specifications and design characteristics shown are subject to change without prior notice.
尺寸規格若有所變更恕不另行通知。

CB-70

頂板專用組合鑽
Construction Line
Boring Machine
for Top Panel

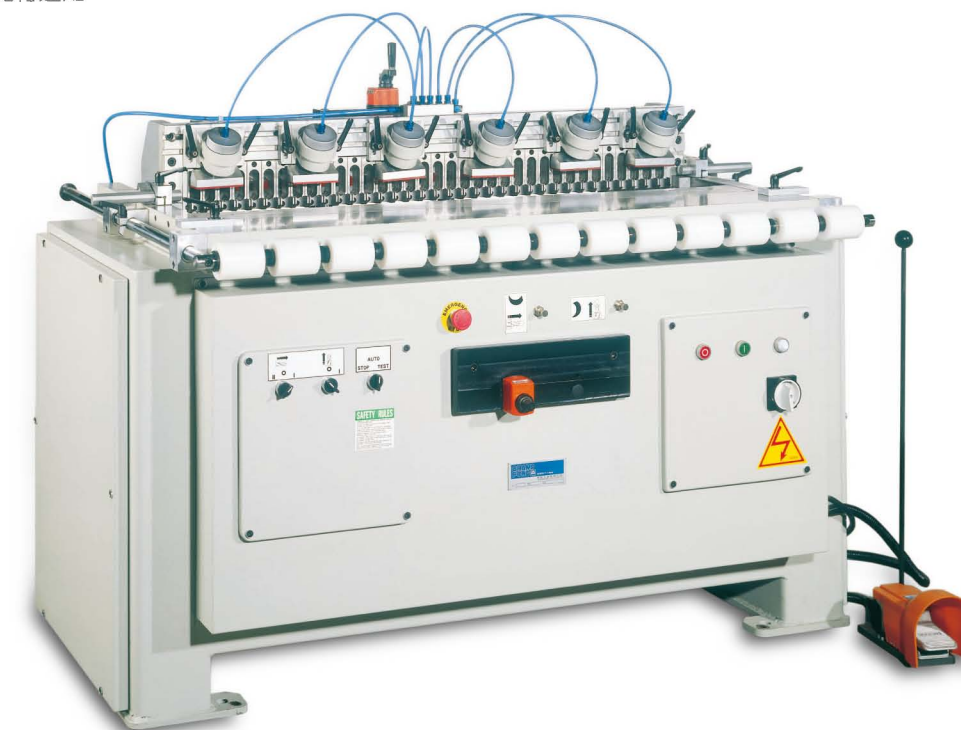

CB-126

Construction Line Boring Machine
for Side Panel / 側板專用六排鑽



CB-70

Construction Line Boring Machine
for Top Panel / 頂底板專用組合鑽



**LB-21i
LB-27i
LB-35Bi**

Single Line Boring Machine /
單排鑽孔機



Top panel, by CB-70.
頂底板使用CB-70加工。



Side panel, by CB-126.
側板使用CB-126加工。

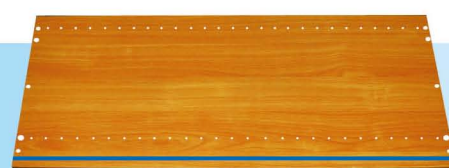

Working sample illustrator:
Modular System Cabinet produced by
Line Boring Partner, i.e. CB-126, CB-70 & LB-21i / 27i / 35i.
加工樣品示意圖：系統櫥櫃可以使用排鑽伙伴，
也就是CB-126, CB-70及LB-21i / 27i / 35i系列機種。

